



Republic of the Philippines
 Department of Agriculture
Philippine Center for Postharvest Development and Mechanization
 Science City of Muñoz, Nueva Ecija
www.philmech.gov.ph
 ISO 9001:2015, ISO 14001:2015, ISO 45001:2018 CERTIFIED



BIDS AND AWARDS COMMITTEE

SUPPLEMENTAL BID BULLETIN NO. 1

**SUPPLY OF LABOR AND MATERIALS FOR THE DESIGN, FABRICATION, DELIVERY
 AND ON-SITE INSTALLATION, TESTING AND COMMISSIONING OF EQUIPMENT AND
 MACHINERIES FOR COCONUT COIR AND PEAT PROCESSING CENTER
 (PHilMech-Goods-23-07-15)**

This **Supplemental/Bid Bulletin No. 1** is being issued to clarify, amend and supplement provisions in the Bidding Documents.

A. ISSUES AND CONCERNS DURING THE PRE-BID CONFERENCE

1. <i>Issue / Proposal: Request for the Hauling Cart's similar figure</i>		
<i>Action Taken/Reply: Request/proposal is granted. Similar figure is hereby attached as Annex A</i>		
2. <i>Issue / Proposal: Request that the material for the hulling cart be GI sheet instead of steel frame</i>		
<i>Action Taken/Reply: The material requirement for hauling cart remains to be stainless steel frames.</i>		
	BEFORE	AFTER
<i>Technical Specifications</i>	3) 6 units Hauling Cart - Materials: stainless steel frames	3) 6 units Hauling Cart - Materials: stainless steel frames; ss 304
3. <i>Issue / Proposal: Request for the provision of more details for motorized twining machine</i>		
<i>Action Taken/Reply: Technical specification is retained.</i>		
4. <i>Issue / Proposal: Inquiry if the project design should be a PCA accredited design or any manufacturer design could be acceptable.</i>		
<i>Action Taken/Reply: The design has no specific requirement. Either PCA or private manufacturer design is acceptable as long as it conforms to the requirements and standards</i>		

Main Office: CLSU, Science City of Muñoz, Nueva Ecija, Philippines
 Mobile Nos.: (+63) 917-800-4526 / (+63) 917-813-0852

Liaison Office: 3rd Floor, ATI Bldg., Elliptical Road, Diliman, Quezon City



5. Issue / Proposal: Clarification regarding the "23KV" specification of the transformer.		
Action Taken/Reply: Requirement for "23KV" is deleted in the transformer specifications		
	BEFORE	AFTER
Technical Specification	3 sets Transformer - Transformer Pole Type, 50 KVA, 23KV, 3Phase, Cu-cu Winding	3 sets Transformer - Transformer Pole Type, 50 KVA, 3Phase, Cu-cu Winding
6. Issue / Proposal: Request for a detailed list of manufacturer's standard tools requirement.		
Action Taken/Reply:		
	BEFORE	AFTER
Technical Specification	With 1 set of manufacturer's standard tools, Heavy Duty Toolbox and accessories required for maintenance	Standard heavy duty tools and accessories: made of tempered steel and chrome vanadium, namely: - Adjustable wrench, 300mm, minimum - Grease gun, 250mm cylinder length, minimum - One (1) set combination wrench (open and box, 10 pcs-size appropriate to the equipment for coco coir and peat) - Screwdriver: Philips and flat head, 300mm, minimum - Heavy duty toolbox and roll-up tools holder * Size that could accommodate the required tools
7. Issue / Proposal: Request that the payment terms be per system instead of 100%.		
Action Taken/Reply: Request /proposal is partially granted. Payment terms is amended		
	BEFORE	AFTER
Special Conditions of the Contract <i>(GCC Clause 2.2)</i>	The terms of payment shall be as follows: a) One Hundred percent (100%) of the Contract Price: upon One Hundred Percent (100%)	The terms of payment shall be as follows: a) One Hundred percent (100%) of the Contract Price: upon One Hundred Percent (100%)

Main Office: CLSU, Science City of Muñoz, Nueva Ecija, Philippines
 Mobile Nos.: (+63) 917-800-4526/ (+63) 917-813-0852

Liaison Office: 3rd Floor, ATI Bldg., Elliptical Road, Diliman, Quezon City



	<p>completion of the project and submission of required documents.</p>	<p>completion of the project and submission of required documents.</p> <p><u>In case of unavailability of the building the following term applies:</u></p> <p>b) <u>Fifty percent (50%) of the Contract Price: upon delivery of the complete components/equipment and initial inspection of the authorized representatives of PHilMech ; and</u></p> <p>c) <u>Remaining Fifty percent (50%) of the Contract Price: upon 100% completion of the project and final inspection and acceptance.</u></p>
<p><i>8. Issue / Proposal: Request for the extension of the delivery period.</i></p>		
<p><i>Action Taken/Reply: The ninety (90) calendar day delivery period is retained.</i></p>		
<p><i>9. Issue / Proposal: Inquiry if the supplier could provide generator set in order for the project to be completed in case there would be a delay in the processing of electrical requirements by the cooperatives counterpart.</i></p>		
<p><i>Action Taken/Reply: Yes. The bidder is allowed to provide generator set for testing purposes</i></p>		
<p><i>10. Issue / Proposal: Inquiry on who will be providing the raw materials for testing.</i></p>		
<p><i>Action Taken/Reply: PHilMech will be providing the samples for testing</i></p>		
<p><i>11. Issue / Proposal: Inquiry if the bidder is allowed to only participate in items 1 and 4</i></p>		
<p><i>Action Taken/Reply: No. The bidding project is a single contract lot, so all components must be supplied</i></p>		
<p><i>12. Issue / Proposal: Inquiry on the reckoning of the one (1) year warranty requirement</i></p>		

Main Office: CLSU, Science City of Muñoz, Nueva Ecija, Philippines
 Mobile Nos.: (+63) 917-800-4526/ (+63) 917-813-0852

Liaison Office: 3rd Floor, AT1 Bldg., Elliptical Road, Diliman, Quezon City



Action Taken/Reply: The one (1) year warranty requirement will start from the day the machine has been tested and accepted by the TPI.

Issued this 25th day of July 2023 in the Science City of Muñoz, Nueva Ecija, Philippines.

Reviewed and approved by:

NELSON C. SANTIAGO, Ph.D.
Chairperson, Bids and Awards Committee

ARLENE C. JOAQUIN
Vice Chairperson

JERRY F. AVELLANOZA
Regular Member

DONALD V. MATEO
Technical Member

ANDRES M. TUATES JR. Ph.D.
End-User/Provisional Member

CONFORMED: _____
Bidders Name: _____
Date Received: _____

ANNEX A.

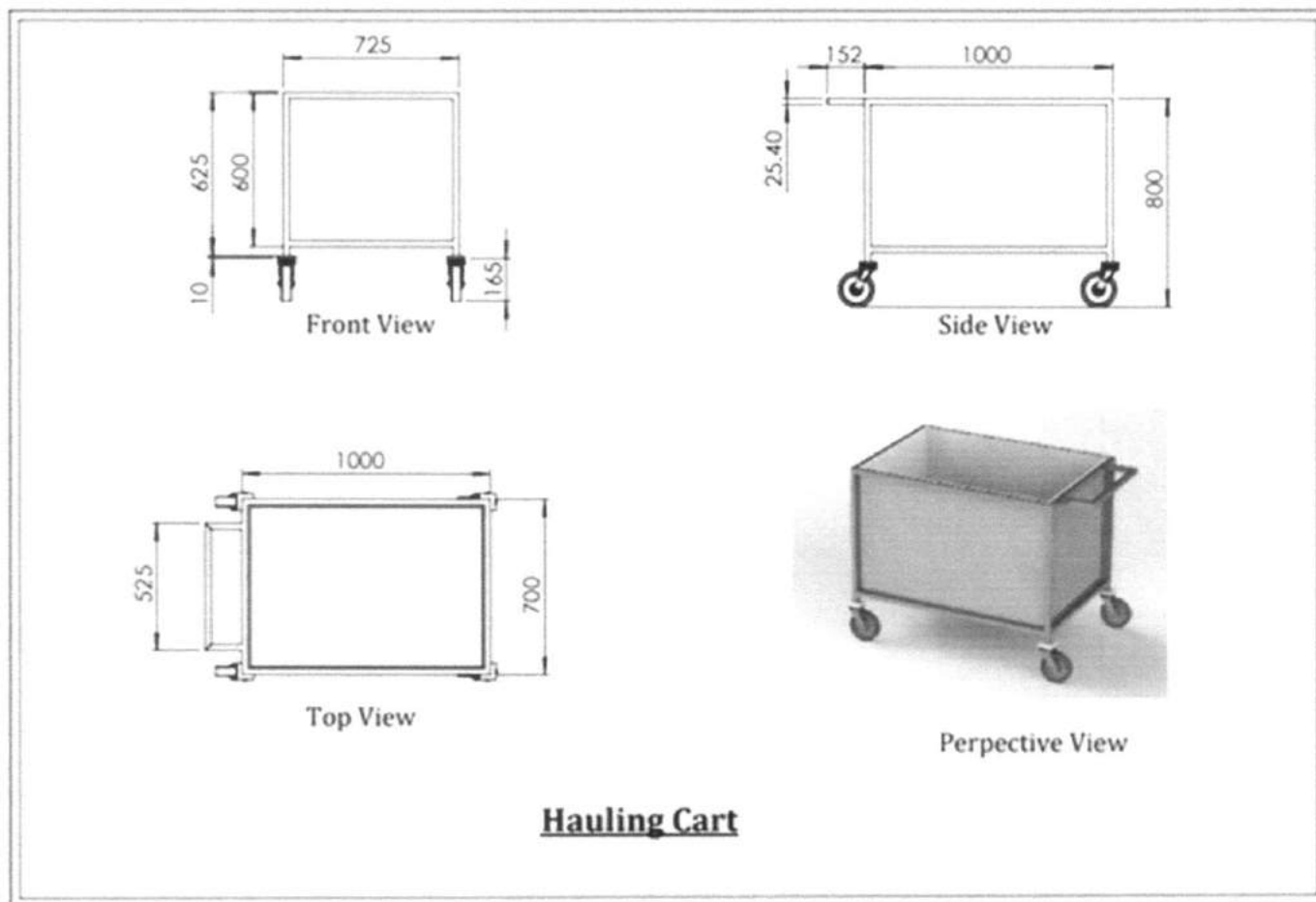

Main Office: CLSU, Science City of Muñoz, Nueva Ecija, Philippines
Mobile Nos.: (+63) 917-800-4526/ (+63) 917-813-0852

Liaison Office: 3rd Floor, AT1 Bldg, Elliptical Road, Diliman, Quezon City

PHilMech-AD-F-192 Rev 01 (07.20.23)